

0.08 M□□  
0.10 M□□ (after reflow soldering)

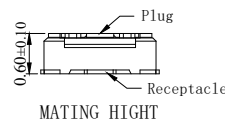

MATING HEIGHT

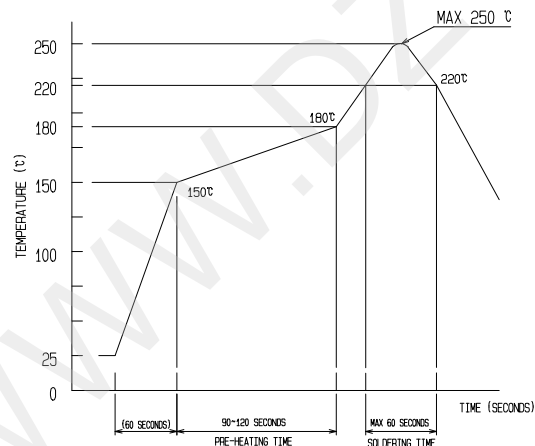

RECOMMENDED REFLOW TEMPERATURE PROFILE  
USIN LEAD-FREE SOLDER PASTE

NOTE:

1: SPECIFICATION:

- 1.1 Voltage Rating: 60V AC/DC
- 1.2 Rated current : For signal pin 0.3 AMPS/Pin  
For power pin 5 AMPS / Pin
- 1.3 Temperature Range: -40 °C to +85°C
- 1.4 Contact Resistance:  
Signal pin: Initial: 50mΩ MAX  
AFTER TEST: Δ20mΩ  
Power pin: Initial: 15mΩ MAX  
AFTER TEST: 15mΩ MAX
- 1.5 Insulation Resistance  
Initial: 1000 MΩ Minimum.  
After test: 1000 MΩ Minimum.
- 1.6 Dielectric Withstanding Voltage  
NO EVIDENCE OF BREAKDOWN IN AC 250 V, 1 MINUTE
- 1.7 MATING-UNMATING FORCE:  
MATING FORCE: 1 CYCLE: 50N MAX  
30 CYCLE: 50N MAX  
UNMATING FORCE: 1 CYCLE: 23.4N MIN  
30 CYCLE: 19.5N MIN
- 1.8 SALT WATER SPRAY: TEMPERATURE 35°C±2°C  
DENSITY OF SALT WATER 5±1%  
DURATION: 48±2 HOUR  
Storage Temperature Range -40°C to +85°C  
0 to 90 % RH (Relative humidity).

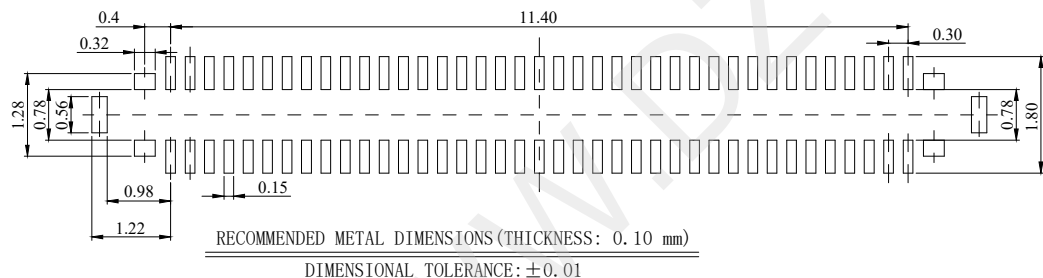
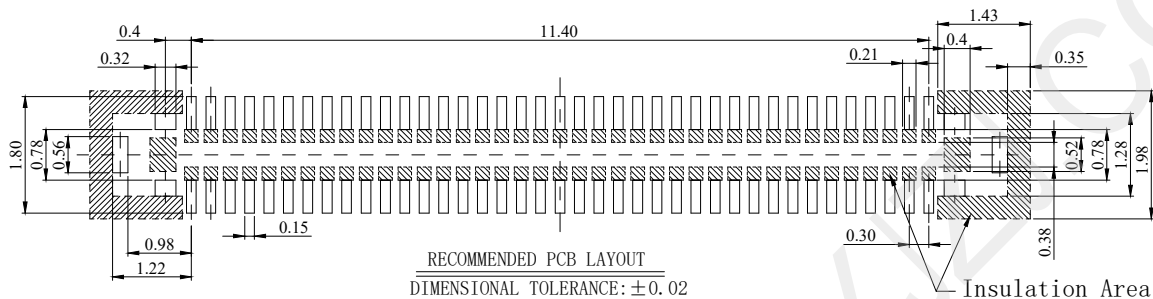

3	POWER CONTACT	COPPER ALLOY, Au10% Min ON CONTACT AREA, Au10% Min ON SOLDER AREA, Ni 50u Min ALL OVER	6	REEL	PLASTIC
2	SIGNAL CONTACT	COPPER ALLOY, Au10% Min ON CONTACT AREA, Au10% Min ON SOLDER AREA, Ni 50u Min ALL OVER	5	COVER TAPE	PLYESTER
1	HOUSING	LCP , BLACK, UL 94 V-0	4	EMBOSSED CARRIER TAPE	PS
NO.	PART NAME	DESCRIPTION , REMARKS	NO.	PART NAME	DESCRIPTION , REMARKS



深圳市华宇创精密电子有限公司

<b>TOLERANCE:</b> X.X ±0.30 X.XX ±0.25 X.XXX ±0.15 X' ±2° X.X' ±0.5° UNIT: mm [inch] SCALE: 1:1 SIZE: A4	<b>DRAWN BY :</b> 陈一鸣	<b>DATE :</b> 2014-02-23	<b>PART NAME:</b> 0.3PH 单槽BTB 公座 78P
	<b>CHECKED BY:</b> 马跃	<b>DATE :</b> 2014-02-23	<b>PART NO.:</b> HYC62M-BTB2X39-049
	<b>APPROVED BY:</b> 邱敏	<b>DATE :</b> 2014-02-23	<b>DRAW NO.:</b> HYC-2511201639
			<b>SHEET NO.:</b> 1 OF 1

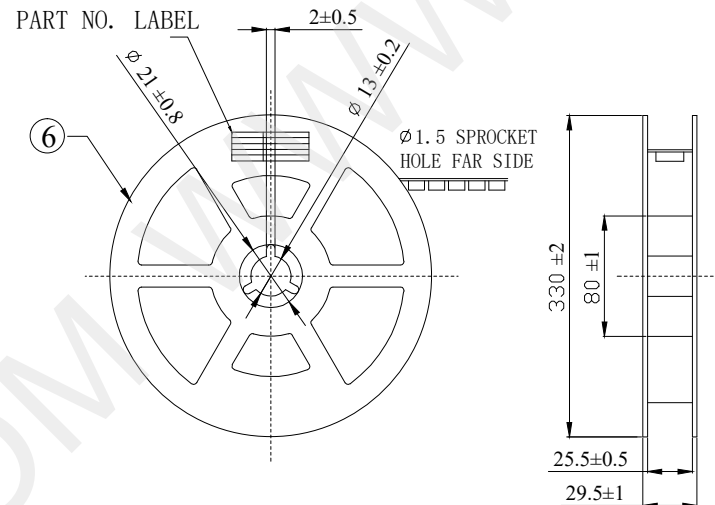
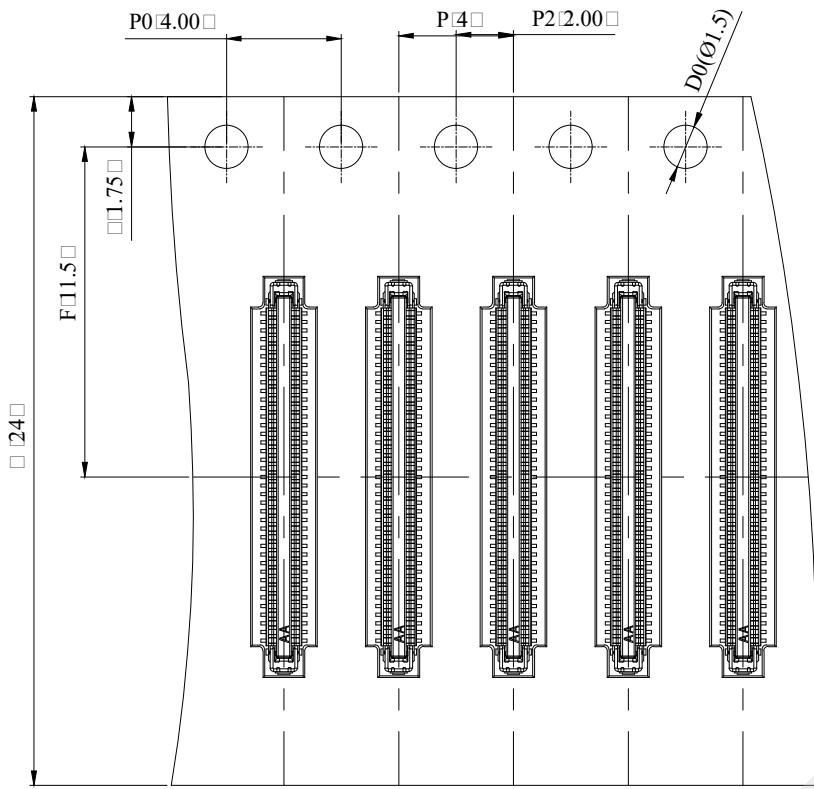

STYLE AND DIMENSION OF REEL

PER REEL 15000 CONNECTORS

DIRECTION OF UNREELING

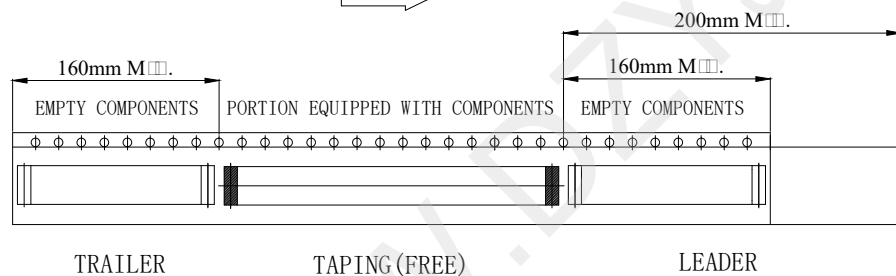

深圳市华宇创精密电子有限公司

TOLERANCE: X.X ±0.30 X.XX ±0.25 X.XXX ±0.15 X.' ±2' X.X' ±0.5'	DRAWN BY : 陈一鸣	DATE : 2014-02-23	PART NAME: 包装图	
	CHECKED BY: 马跃	DATE : 2014-02-23	PART NO.	
UNIT: mm [inch] SCALE:1:1 SIZE: A4	APPROVED BY: 邱敏	DATE : 2014-02-23	MOLD NO.	
			DRAW NO:	
			SHEET NO.	1 OF 1

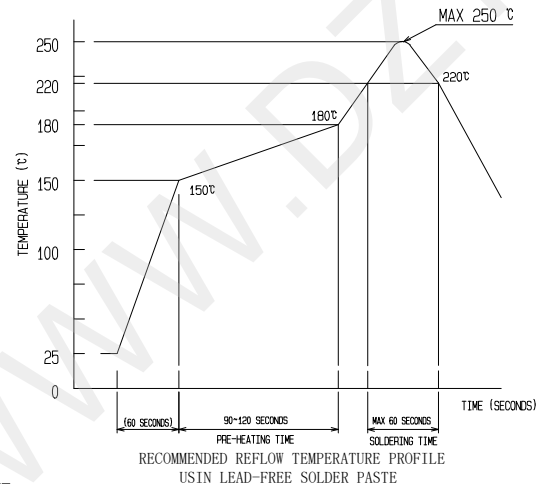
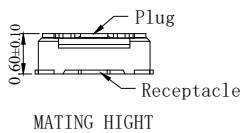
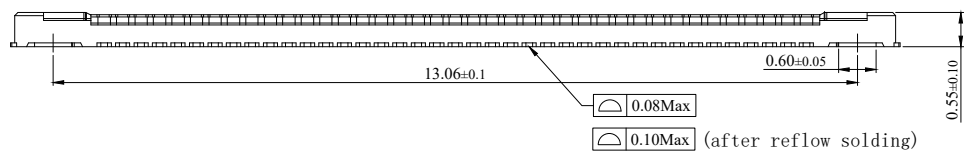
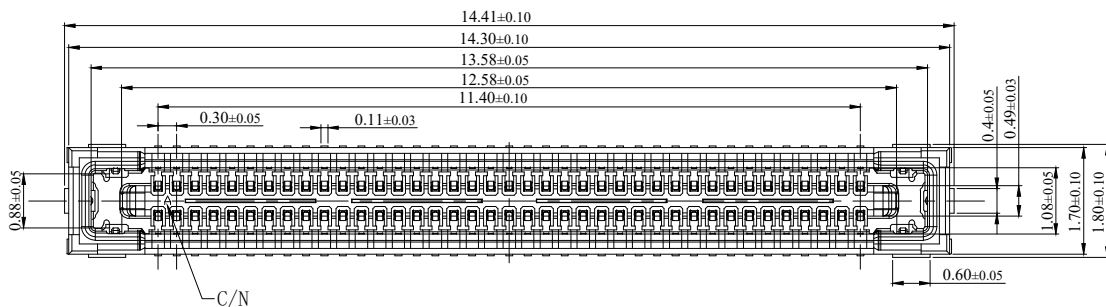

NOTE:

1: SPECIFICATION:

- 1.1 Voltage Rating: 60V AC/DC
- 1.2 Rated current : For signal pin 0.3 AMPS/Pin  
For power pin 5 AMPS / Pin
- 1.3 Temperature Range: -40 °C to +85°C
- 1.4 Contact Resistance:  
Signalpin:Initial:50mΩ MAX  
AFTER TEST:Δ20mΩ  
Power pin:Initial:15mΩ MAX  
AFTER TEST:15mΩ MAX
- 1.5 Insulation Resistance  
Initial: 500 MΩ Minimum.  
After test: 500 MΩ Minimum.
- 1.6 Dielectric Withstanding Voltage  
NO EVIDENCE OF BREAKDOWN IN AC 250 V,  
1 MINUTE
- 1.7 MATING-UNMATING FORCE:  
MATING FORCE: 1 CYCLE: 40N MAX  
30 CYCLE:40N MAX  
UNMATING FORCE:1 CYCLE: 10N MIN  
30 CYCLE:8N MIN
- 1.8 SALT WATER SPRAY: TEMPERATURE 35°C±2°C  
DENSITY OF SALT WATER 5±1%  
DURATION:48±2 HOUR  
Storage Temperature Range -40°C to +85°C  
0 to 90 % RH (Relative humidity).

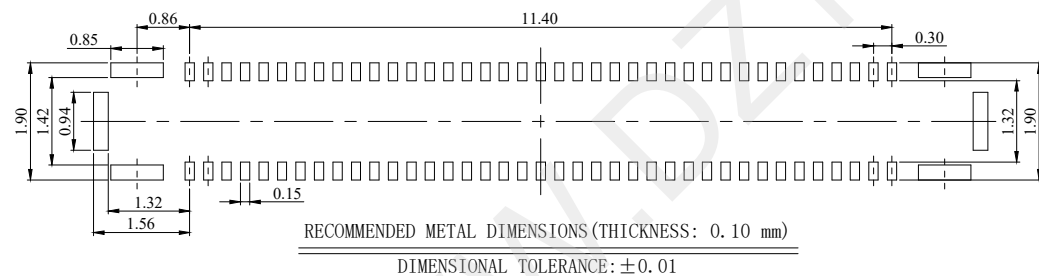
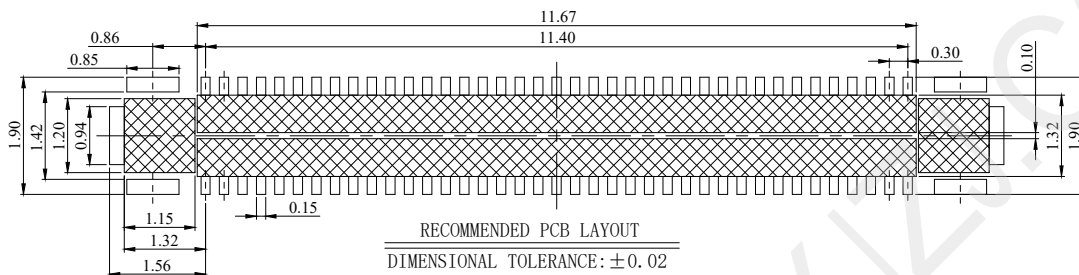

3	POWER CONTACT	COPPER ALLOY, AuSn <sup>2</sup> Min ON CONTACT AREA, AuSn <sup>2</sup> Min ON SOLDER AREA, Ni 50μm Min ALL OVER	6	REEL	PLASTIC
2	SIGNAL CONTACT	COPPER ALLOY, AuSn <sup>2</sup> Min ON CONTACT AREA, AuSn <sup>2</sup> Min ON SOLDER AREA, Ni 50μm Min ALL OVER	5	COVER TAPE	PLLYESTER
1	HOUSING	LCP ,BLACK, UL 94 V-0	4	EMBOSSED CARRIER TAPE	PS
NO.	PART NAME	DESCRIPTION , REMARKS	NO.	PART NAME	DESCRIPTION , REMARKS



## 深圳市华宇创精密电子有限公司

<b>TOLERANCE:</b> X.X ±0.30 X.XX ±0.25 X.XXX ±0.15 X' ±2' X.X' ±0.5'	DRAWN BY : 陈一鸣	DATE : 2014-02-23	PART NAME: 0.3PH 单槽BTB 母座 78P
	CHECKED BY: 马跃	DATE : 2014-02-23	PART NO. HYC62F-BTB2X39-055
UNIT: mm [inch] SCALE:1:1 SIZE: A4	APPROVED BY: 邱敏	DATE : 2014-02-23	DRAW NO: HYC-2511201644
			SHEET NO. 1 OF 1

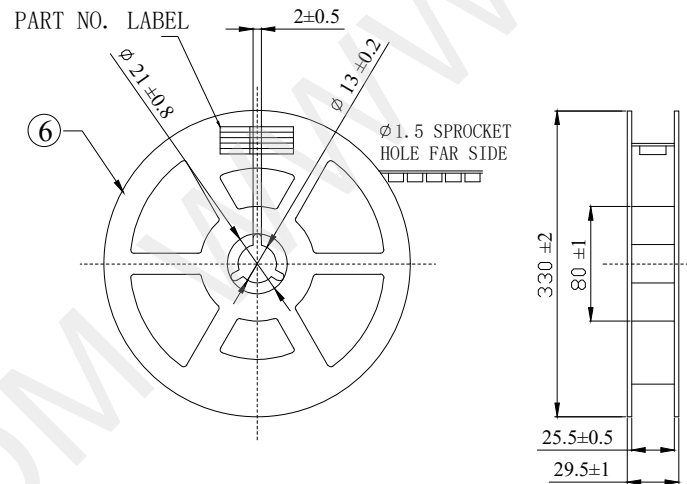
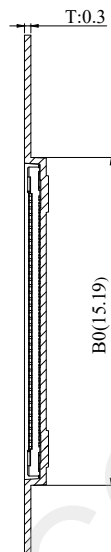
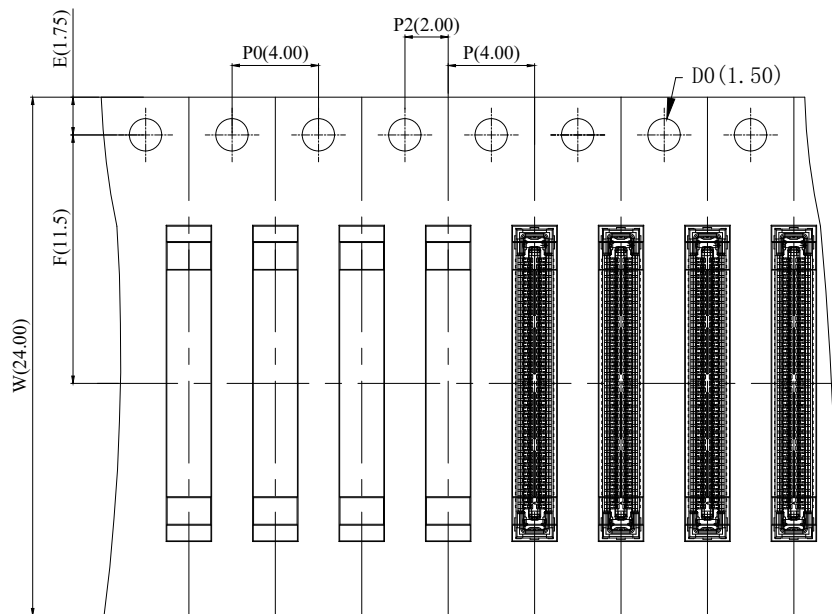

STYLE AND DIMENSION OF REEL  
PER REEL 15000 CONNECTORS

DIRECTION OF UNREELING

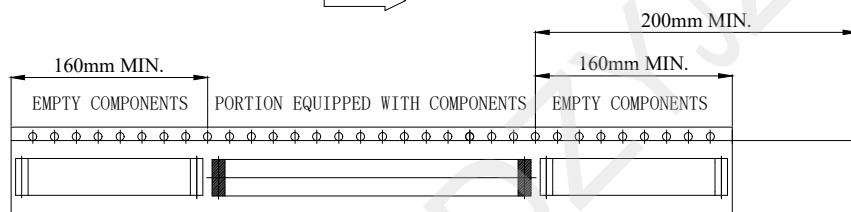

TRAILER

TAPING (FREE)

LEADER



深圳市华宇创精密电子有限公司

TOLERANCE:

X.X ±0.30  
X.XX ±0.25  
X.XXX ±0.15

X' ±2' X.X' ±0.5'

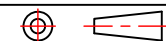

UNIT: mm [inch]

SCALE:1:1 SIZE: A4

DRAWN BY :

陈一鸣

DATE :

2014-02-23

PART NAME:

包装图

CHECKED BY:

马跃

DATE :

2014-02-23

PART NO.

MOLD NO.

APPROVED BY:

邱敏

DATE :

2014-02-23

DRAW NO:

SHEET NO.

1 OF 1